

hergöm

E-20 SE



USE AND MAINTENANCE INSTRUCTIONS INSTRUCTIONS

WELCOME to the HERGÓM family.

We would like to thank you for choosing our E-20 SE Stove, which represents, in technique and style, a significant improvement on typical wood stoves.

Your new Stove is, perhaps, the most advanced solid fuel heating system known today. Owning a HERGOM Stove displays an exceptional sense of quality.

Please read this manual in full. Its purpose is to familiarise users with the device by explaining extremely useful installation, operational and maintenance instructions. Keep this manual at hand for future reference whenever necessary.

If, after reading this manual, you should require any further clarification, please consult your regular dealer.

INDUSTRIAS HERGÓM, S.L., may not be held liable for any damages caused by alterations in its products that have not been authorised in writing, or for defective installation work.

Furthermore, it reserves the right to change its products without prior warning.

Industrias Hergóm, S.L. domiciled in Soto de la Marina (Cantabria) - Spain, offers a **THREE YEARS** warranty on its products. Industrias Hergóm, S.L. guarantees the existence of repair parts and adequate technical service for 10 years from the date on which this product ceases to be manufactured.

The geographical coverage of the said warranty only includes the countries in which Industrias Hergóm, S.L., a subsidiary company or an official importer distribute its products and where Community Directive 2019/771/UE is in force.

The warranty comes into force on the purchase date of the product as indicated on the warranty document and only covers damage or breakages due to manufacturing defects.

IMPORTANT NOTE

If the device is not installed correctly, it will not provide the excellent service for which it has been designed. Please, read these instructions in full and trust the work to a specialist.

The surface of your device is protected by a coat of special anti-heat paint that resists high temperatures. When lighting the fireplace for the first few times, the said paint may emit some fumes. This is normal and is due to the evaporation of certain components of the paint while it adapts to the heat. We, therefore, recommend ventilating the room until this phenomenon ceases to appear.

1- INTRODUCTION

IMPORTANT! All local regulations, including those that refer to national or European regulations, must be applied when installing this device.

The way the E-20 SE Stove is installed will decisively affect safety issues and its correct operation.

It is important to install the fireplace correctly. For the correct installation of the E-20 SE Stove and chimney, we recommend the installation be performed by a professional.

The E-20 SE Stove provides heat by radiation; directly heating walls, ceilings...

2- PRESENTATION

E-20 SE wood stove have the following main features:

- Made of cast iron, with parts that are assembled, sealed and screwed together.
- They are designed for use with firewood only.
- They can burn pieces of wood up to 45cm. in length.
- Self-cleaning glass.
- Hinged front door with ceramic glass pane.
- Ash pan door sealed.
- Vertical top smoke flue of 150 mm of diameter.
- It gives up its heat by radiation, directly heating walls, ceilings, etc.
- Fully factory assembled, ready for connection to the chimney.

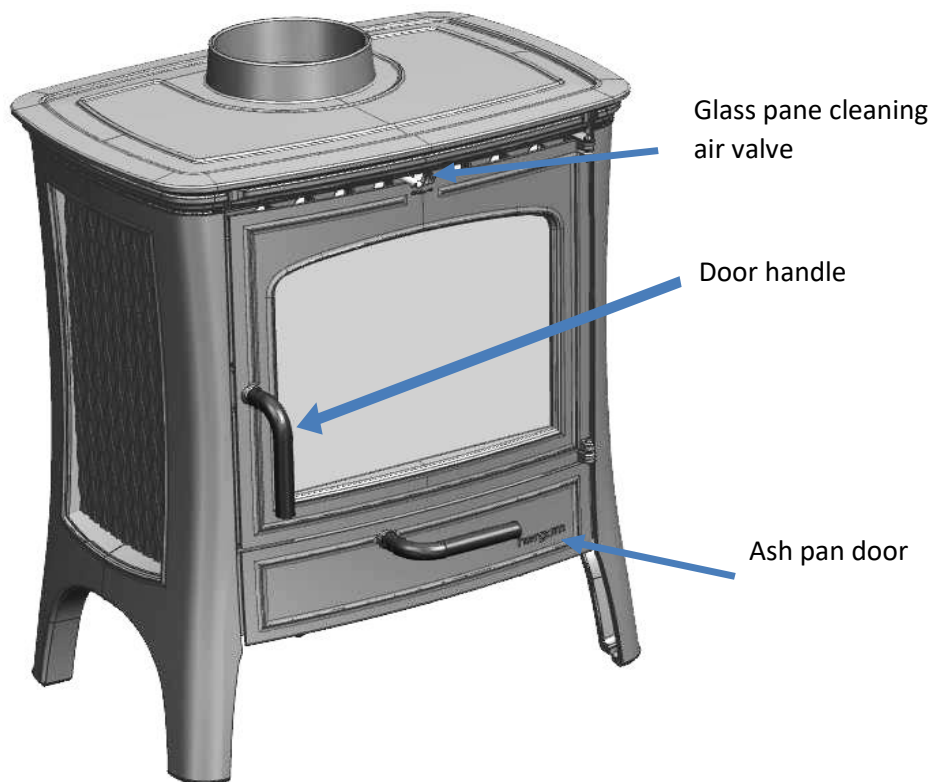

Fig. 1

3- USING THE STOVE

Once your stove has been installed and connected to the chimney, you are ready to light the fire.

Although your stove is easy to use, the combustion process of solid fuels is complicated, as it involves several factors and it takes time and experience to understand the process.

Before lighting your stove for the first time, please take time to become familiar with the different control systems and parts of the unit, how to choose the wood, how to light it and use it on a daily basis.

ALWAYS KEEP IN MIND that the stove generates heat and, therefore, keep children, clothing, furniture... at a distance to prevent burns from direct contact with the appliance.

Below, we have included some advice on your stove and on its use. Please read with care.

HANDLES

To open the hearth door, turn the lever in a clockwise direction until the open position ("Ten To" position on the clock) and gently pull outwards.

To close it, keep the lever in the open position ("Ten To" position on the clock) close the door, by exerting a slight pressure and turn the lever gently in an anti-clockwise direction until the closed position ("Twenty To" position on the clock).

To open the ash pan door, turn the lever in an anti-clockwise direction, from the horizontal closed position to the vertical open position, and gently lower the door.

To close it, reverse the operation. Keep the lever in the vertical position, close the door, by exerting a slight pressure and turn the lever gently in a clockwise direction until the horizontal closed position.

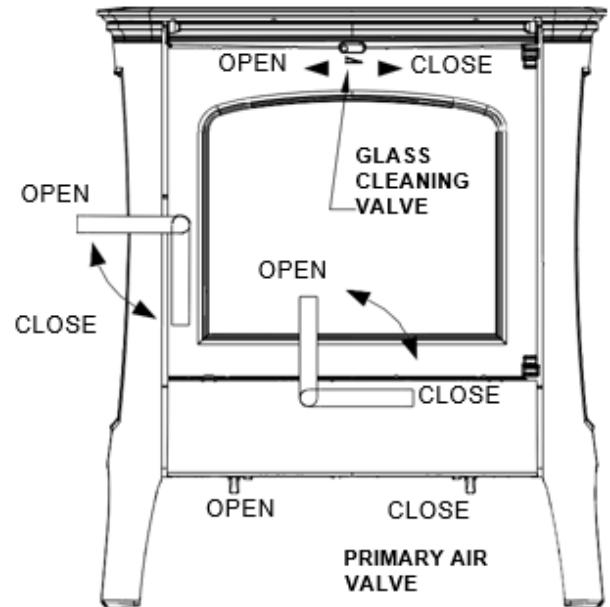

Fig. 2

FIRST LIGHTING UP

Important at first start: may come off a few drops of condensed water from the stove, produced by the humidity of the environment where the stove was stored.

It is very important that the first time the heater is lit, it is done so slowly.

This is for the following reasons:

- Stabilise cast iron parts.
- Harden the joint sealant putty.

Advise:

- We recommend that the first loads of fuel be small.
- To generate draw, heat the chimney by introducing some burning paper in the gap between the front and the deflector, directing it toward the chimney.
- While lighting for the first time, ensure the room where the heater is located is well ventilated as the paint work may let off some fumes.
- Keep the stove on for a few hours at this intensity.

- **IMPORTANT!** The total height of the fire load should not exceed 50% of the height of the combustion chamber.
- **The heater must be closed at all times during combustion to prevent smoke from leaking out. Only open to add fuel.**

Daily use

After lighting up for the first time, your heater will be ready for daily use.

Your heat requirements will be obtained based on the frequency and the amount of firewood you load.

When your heater is cold, we recommend lighting it up slowly.

Overheating.

Overheating means that you have operated your heater at an excessively high temperatures for a long period of time. This can damage your appliance and, therefore, it is a situation that must be avoided.

Overheating is the result of excessive draw, due to any of the following reasons:

- The chimney is too big.
- Improper maintenance of the stove, which may result in air infiltration.
- Inappropriate fuel that produces high temperatures.
- Door not closed correctly.

ATTENTION!

During the operation of the stove, the ash pan door must be perfectly closed.

4- CLEANING & MAINTENANCE

Your heater is a device that is subjected to extreme temperatures and to the corrosive effects of combustion residual materials. Regular maintenance is essential for a longer life and improved user experience. We recommend performing the following inspections frequently.

DURING THE SEASON

- Perform a visual inspection of the chimney. Clean soot and tar if they have begun to accumulate on the inner walls of the heater.
- Check whether the doors close tightly; adjust if necessary.

AT THE END OF THE SEASON

- Inspect and clean the chimney.
- Use the vacuum cleaner to clean inside the heater and inspect it.
- Any soot and tar (creosote) that has accumulated on the walls of the heater will hinder performance.
- Inspect door seals. These should be replaced when they no longer seal the door perfectly.
- In the case of painted heaters, paint the cast iron parts again if necessary.

CLEANING

Cleaning should always be performed when the heater is cold.

Cleaning ash.

These heaters are equipped with an ash pan located at the bottom of the heater.

Remove the ash pan and remove the ash.

Ash should be emptied into a metal container and immediately removed from the house.

If necessary clean the ash pan housing.

Painted parts

Clean with a dry cloth to avoid rust.

Chimney and connecting unit

Read the chapter in the Manual for Installers that refers to this topic.

DOOR PANES

Cleaning

Fireplace window cleaning liquids are quite effective products.

Never try to clean the glass while the fireplace is working.

If the glass pane on the fireplace door is constantly covered in soot, this means your fire is “poor” and that the connecting pipe and chimney are being blocked by soot and creosote.

Replacing.

The glass panes in your heater have been especially manufactured for log stoves.

If they should break, they must be replaced by another glass pane with the same technical specifications. Contact our Distributor to provide you with the appropriate glass pane, together with instructions to assemble and seal.

MAINTENANCE PRODUCTS

Industrias HERGÓM, S.L. places a range of products for the preservation of your heater and chimney at your disposal: heat resistant paint, refractory putty, glass cleaning products.

5 – PRODUCT RECYCLING

Your appliance is delivered packed in plastic and a cardboard box on a wooden pallet. You can use cardboard and wood as fuel for the first lightings of the appliance, or take it to a local recycling point. The plastic that protects the device must be taken to a specific local recycling point or center, it must not be disposed of in conventional waste dumpster.

All local regulations, including those that refer to national or European regulations, must be applied when recycling this device at the end of its useful life. The product should never be disposed of in conventional waste dumpster. Its appliance is made up of components made of cast iron, steel, glass, insulating materials and electrical material, which are assembled using screws and rivets. You can disassemble it and take it to a specific local recycling point or center. Glass should not be disposed of in conventional waste dumpster.

6- SAFETY

WARNING!

Gas/log/pellet units get hot when in use.

Consequently, owners must act with precaution and keep at a distance. Especially keep children, the elderly and other people who require special supervision, as well as pets, away from the fireplace when it is in use.

Make sure that children or other people who are not familiar with how the device works are supervised by responsible people when they are near the fireplace.

In order to prevent burns or children or other people from coming near the appliance, use a fire grille or screen.

A number of possible risks are present when operating your solid fuel oven with fuel of any brand. The said risks can be minimised if the instructions and recommendations included in this manual are followed.

- When installing the stove, observe the necessary safety distances for the oven and chimney from combustible surfaces (wooden or papered walls, wooden floors...). Safety distances must be respected when the lining on walls or nearby areas may be damaged or deformed by temperature (varnish, paint, PVC...). **Fig. 3.**

- The base where you are going to install your heater must be flat and provide a perfect seat. The said base must also be capable of supporting the weight of the heater. The base must be built using heat resistant materials.

THIS STOVE MUST NEVER BE INSTALLED ON A FLOOR DETERIORABLE BY HEAT (NON-FLAMMABLE)

- All the area around the heater should must be heat resistant. If not, they must be protected by fire-proof material.

- Ash should be emptied into a metal container and immediately removed from the house.
- Do not use flammable liquids to light the stove. Keep any type of flammable liquid (petrol, gasoline, alcohol,...) at a distance from the fireplace.
- Never use coal or fuels that are not recommended for the operation of this product.
- Periodically inspect the chimney and clean whenever necessary. Also inspect the state of joints, glass, screws...
- **Protect your hands with a glove or other insulating material because, during operation, the opening and closing handle will be hot.**

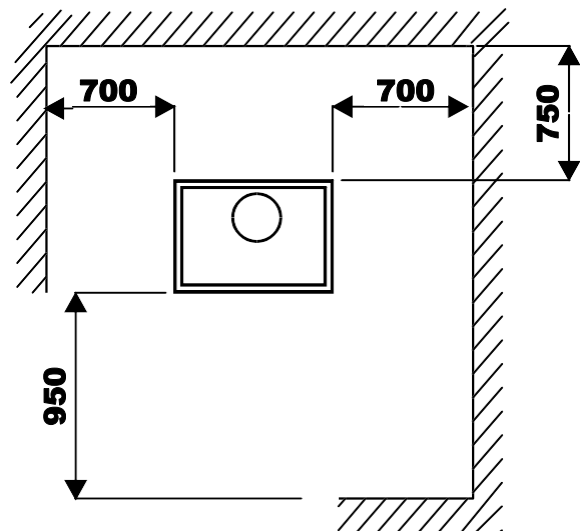

Fig. 3

7 - PROBLEMS WITH THE DRAW

Below is a list of the most common problems that affect any type of heater. All these problems can be corrected and, sometimes, only require slight adjustments to make the heater work correctly.

Remember that the weather affects the way your heater works.

If your heater release fumes inside the home, the following may be the cause:

If you have a newly built chimney:

- a) The draw may be poor.
- b) The diameter or height may not be correct.
- c) The system may be partially blocked.

In the case of a previous chimney:

- a) Soot may be obstructing the chimney partially.
- b) There may be an internal or external crack through which air may be entering.
- c) The diameter or height may be not be correct for the new device.

We recommend reading the chapter of the **MANUAL FOR PROFESSIONAL INSTALLERS** and revising all the information referring to Chimneys.

8 - DIMENSIONES / MEASURES / DIMENSIONS / DIMENSIONI / DIMENSÕES

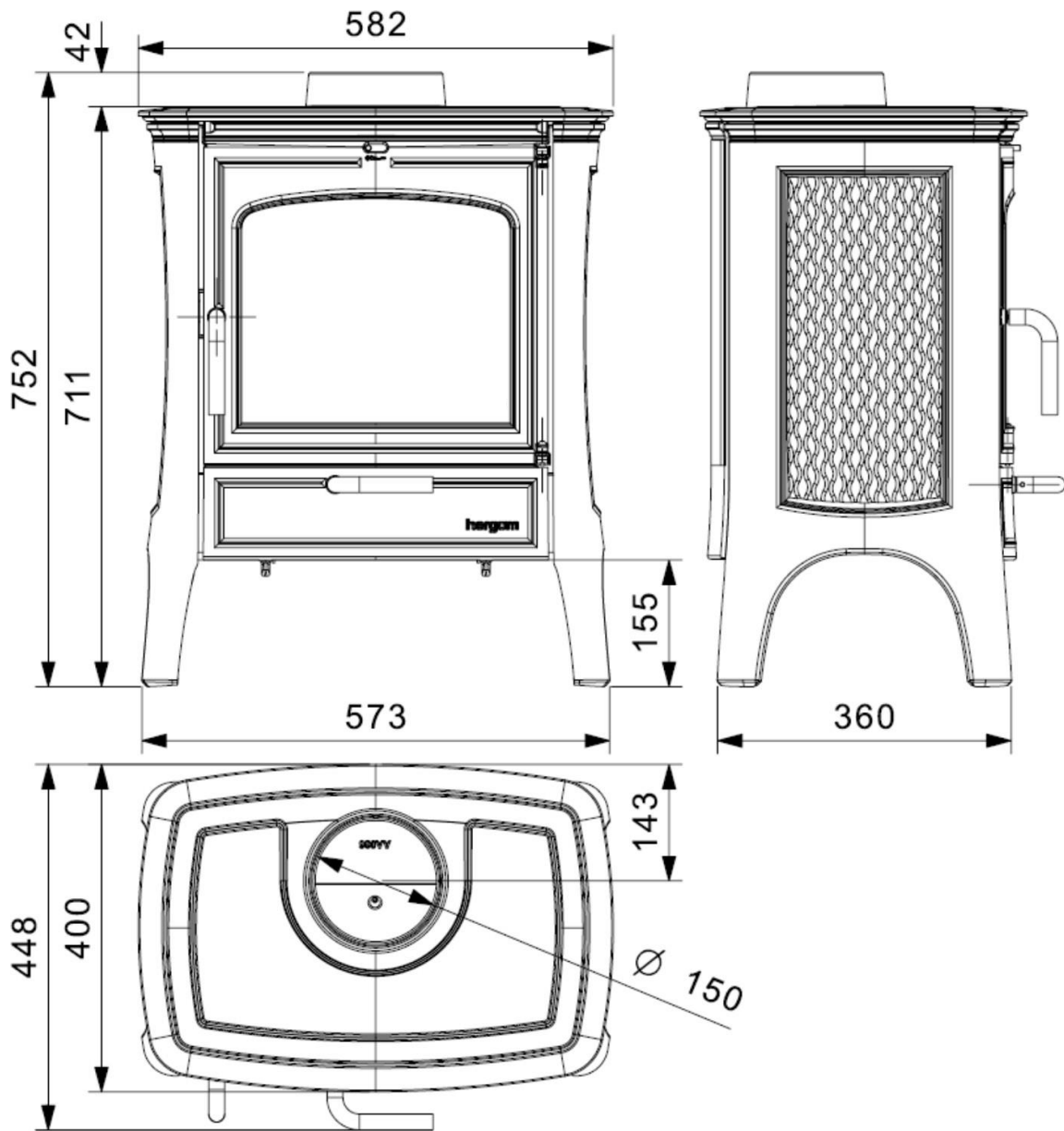

9 - DATOS TECNICOS / TECHNICAL DATA / DONNÉES TECHNIQUES / DATI TECNICI / DADOS TÉCNICOS

Potencia Nominal / Nominal power / Puissance nominale / Potenza nominale / Potência nominal ** (KW)	5,7	
Temperatura de los gases medio / Average smoke temperatura / Temperature moyenne de gaz / Temperatura media del gas / Temperatura media dos gases (°C)	253	
Temperatura media en collarín de salida / Average temperature at flue ring / Température moyenne dans le collier de sortie / Temperatura media nel giunto di uscita / Temperatura média no colarim de saída (°C)	304	
Caudal másico de los humos / Mass flow rate of smoke / Débit massique des fumées/ Flusso del fumo / Caudal mássico dos fumos (gr/seg)	5,9	
Concentración de CO medio / CO emissions / Concentration moyenne de CO / Concentrazione media di CO / Concentração de CO médio (13% O2 – Vol. %)	0,1	
Rendimiento / Efficiency / Rendement / Prestazione / Rendimento (%)	80	
Admite troncos de leña de longitud / Accepts logs of the following length / Admet des buches de bois d'une longueur de / Accetta tronchi di legna da ardere di lunghezza / Admite troncos de lenha de comprimento (mm)	420	
Puerta Frontal / Fire door / Porte frontale / Sportello frontale / Porta frontal:	Alto / Height / Hauteur / Altezza / Alto: (mm)	400
	Ancho / Width / Largeur / Larghezza / Largura: (mm)	450
Collarín de humos / Smoke collar / Colerette de fumees / Giunto uscita fumi / Colarim de fumos (Ø mm)	150	
Chimenea metálica / Metal chimney / Cheminee metallique / Caminetto in metallo / Chaminé metálica (Ø mm)	150	
Altura recomendada de chimenea / Recommended chimney height / Hauteur de cheminee recommandee / Altezza camino consigliata / Altura recomendada da chaminé (m)	5 – 6 *	
Chimenea de albañilería mínimo aproximado / Masonry chimney min. approx. / Cheminee de Maçonerie minimum approximatif / Camino minimo approssimativo in muratura / Chaminé de alvenaria mínimo aproximado (mm)	175 x 175	
Tiro recomendado / Recommended draw / Tirage recommandé / Tiraggio consigliato / Tiragem recomendada (Pa)	20	
Salida de humos / Smoke outlet / Sortie des fumées / Uscita fumi / Saída de fumos	Vertical	
Peso / Weight / Poids / Peso / Peso (Kg)	90	

* Para otras medidas consultar al Distribuidor o al Fabricante. (Valores Aproximados.)

Estufa homologada siguiendo las especificaciones de la norma UNE-EN 13240:2002 "Estufas que utilizan combustibles sólidos – Requisitos y métodos de ensayo", modificada por UNE-EN 13240/AC y UNE-EN 13240:2002/A2.

¡ADVERTENCIA! Su estufa no debe ser utilizada como incinerador y no deben utilizarse otros combustibles (plásticos, aglomerados, etc). Utilice los materiales recomendados.

No usar como combustible maderas que provengan del mar. Las sales contenidas en ella reaccionan en la combustión liberando ácidos que atacan al hierro y acero.

* In the case of other dimensions consult your Dealer or the Manufacturer (Approximate Values) **Stove approved based on the specifications provided in UNE-EN 13240:2002 "Room heaters fired by solid fuel - Requirements and test methods", as amended by UNE-EN 13240/AC and UNE-EN 13240:2002/A2.**

ATTENTION! Your heater should not be used as an incinerator and no other types of fuel should be used (plastic, chipboard...). Use recommended materials only.

Do not wood washed ashore from the sea as fuel. The salt contained in it will react in the combustion process and release acid that will damage the iron and steel.

* Pour d'autres mesures, consultez le distributeur ou le fabricant (valeurs approximatives).

Poêle homologué conformément aux spécifications de la norme UNE-EN 13240:2002 "Appareils de chauffage utilisant du combustible solide - Exigences et méthodes d'essai » modifiée par UNE-EN 13240/AC et UNE-EN 13240:2002/A2.

AVERTISSEMENT! Votre poêle ne doit pas être utilisé comme incinérateur et il ne faut pas utiliser d'autres combustibles (plastiques, agglomérés, etc.) que ceux recommandés.

N'utilisez pas comme combustible de bois rejeté par la mer. Les sels qu'il contient réagissent à la combustion en libérant les acides qui attaquent le fer et l'acier.

* Per altre misurazioni consultare il distributore o il produttore. (Valori approssimativi.)

Stufa omologata secondo le specifiche della normativa UNE-EN 13240: 2002 "Stufe che utilizzano combustibili solidi - Requisiti e metodi di testaggio", modificata da UNE-EN 13240/AC e UNE-EN 13240: 2002/A2.

ATTENZIONE! La stufa non deve essere utilizzata come inceneritore e non devono essere utilizzati altri combustibili (plastica, agglomerati, ecc.). Usare i materiali consigliati.

Non utilizzare legna proveniente dal mare come combustibile. I sali in essa contenuti reagiscono nella combustione rilasciando acidi che attaccano il ferro e l'acciaio.

*Para outras medidas, consultar o Distribuidor ou o Fabricante. (Valores Aproximados.)

Estufa homologada seguindo as especificações da norma UNE-EN 13240:2002 "Estufas que utilizam combustíveis sólidos – Requisitos e métodos de ensaio", modificada pela UNE-EN 13240/AC e a UNE-EN 13240:2002/A2.

ADVERTÊNCIA! Esta estufa não deve ser utilizada como incinerador e não se deve de utilizar outros combustíveis (plásticos, aglomerados, etc). Utilize os materiais recomendados.

Não utilizar como combustível madeiras que venham do mar. Os sais que contêm reagem na combustão liberando ácidos que atacam o ferro e o aço.

10 – COMPONENTES DE LA ESTUFA / EXPLODED VIEW / EXPLOSÉ / COMPONENTI / EXPLODIDO

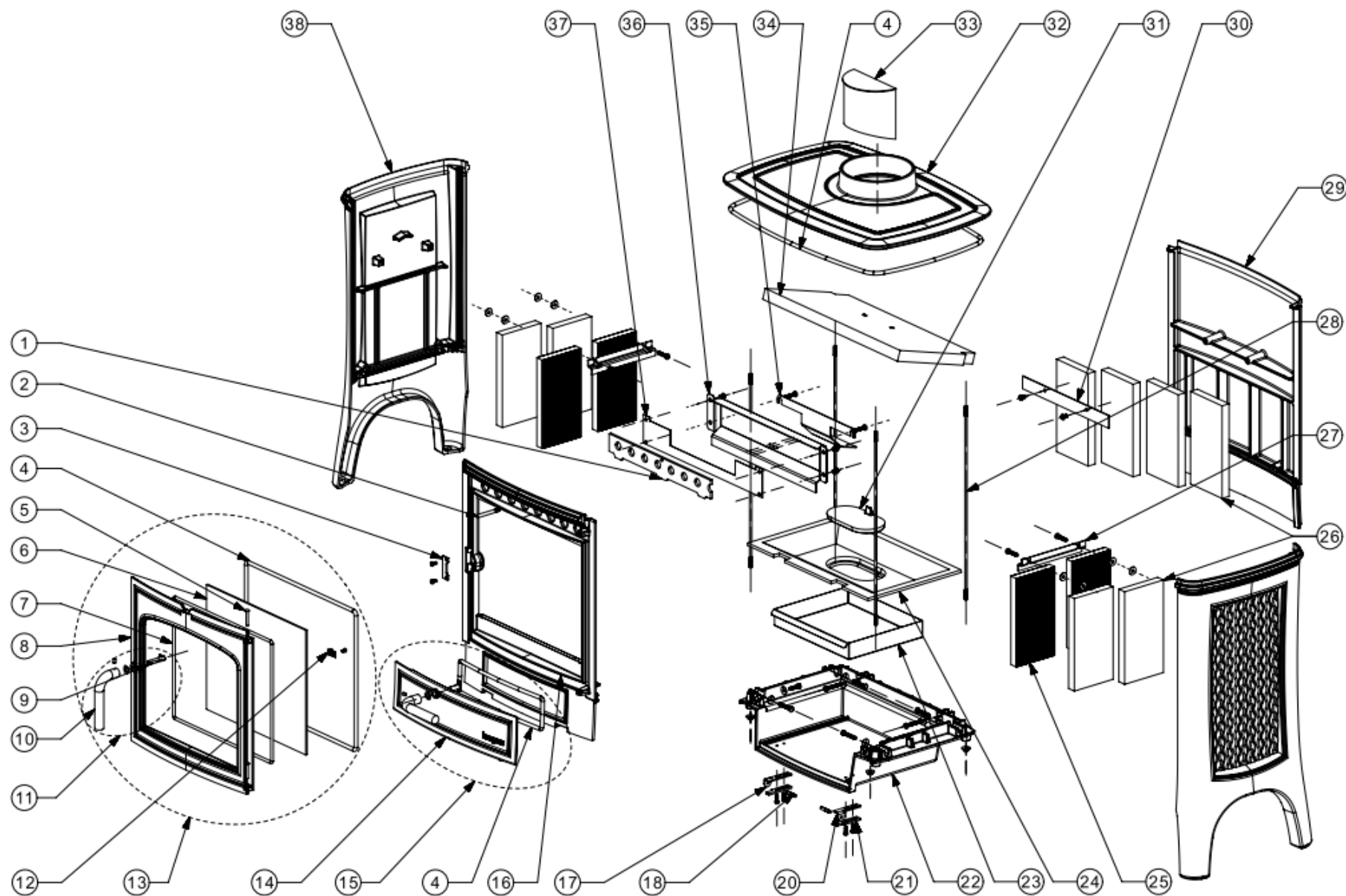

PC NO	PART NAME	QTY
1	9917514	1
2	9900859	1
3	9917028	1
4	99J38	1
5	99T316	2
6	9920763	1
7	99J14	1
8	9917020	1
9	9901355	2
10	9915861	2
11	9920761	2
12	9917002	3
13	9920764	1
14	9917024	1
15	9920762	1
16	9915852	1
17	9917463	1
18	99T1472530	2

PC NO	PART NAME	QTY
20	9917463	1
21	9917463	2
22	9920765	1
23	9920758	1
24	9906833	1
25	9901053	4
26	9901049	8
27	9921187	2
28	99T5460	4
29	9920754	1
30	9921188	1
31	9920095	1
32	9920753	1
33	9921146	1
34	9921147	1
35	9921148	1
36	9921184	1
37	9921149	1
38	9915850	2

Se recomienda usar piezas de repuesto recomendadas por el fabricante.

INDUSTRIAS HERGÓM, S.L. declina toda responsabilidad derivada de una instalación defectuosa o de una utilización incorrecta y se reserva el derecho de modificar sus productos sin previo aviso.

La responsabilidad por vicio de fabricación, se someterá al criterio y comprobación de sus técnicos, estando en todo caso limitada a la reparación o sustitución de sus fabricados, excluyendo las obras y deterioros que dicha reparación pudiera ocasionar.

We recommend using spare parts recommended by the manufacturer.

INDUSTRIAS HERGÓM, S.L., rejects any liability derived from a faulty installation or incorrect use and reserves the right to alter its products without prior warning.

Any liability due to manufacturing defects will be subject to the criteria and verification of the company’s experts and will be limited to the repair or replacement of its products, excluding any construction work or damage the said repairs may cause.

Nous conseillons l’utilisation des pièces de rechange recommandées par le fabricant.

INDUSTRIAS HERGÓM, S.L. décline toute responsabilité relative à une installation défectueuse ou à une utilisation incorrecte et se réserve le droit de modifier ses produits sans avertissement préalable

La responsabilité pour vice de fabrication sera soumise au critère et à l’approbation de ses experts techniciens et se traduira, limitée dans tous les cas, par la réparation ou le remplacement de ses pièces fabriquées excluant les ouvrages et détériorations qui découleraient de cette réparation.

Si consiglia di utilizzare solo parti di ricambio consigliate dal produttore.

INDUSTRIAS HERGÓM, S.L. declina ogni responsabilità derivante da un’installazione non corretta o da un uso errato e si riserva il diritto di modificare i propri prodotti senza preavviso.

La responsabilità per difetti di fabbricazione sarà soggetta al giudizio e alla verifica dei suoi tecnici e, in ogni caso, sarà limitata alla riparazione o alla sostituzione dei suoi prodotti, ad esclusione dei lavori e i danni che tale riparazione può causare.

Recomenda-se utilizar peças sobressalentes recomendadas pelo fabricante.

A INDUSTRIAS HERGÓM, S.L. declina qualquer responsabilidade derivada de uma instalação defeituosa ou de uma utilização incorreta e reserva-se o direito de modificar os seus produtos sem aviso prévio.

A responsabilidade por vício de fabricação, será submetida ao critério e à verificação dos técnicos da empresa Hergom e estará sempre limitada à reparação ou substituição dos seus produtos, excluídas as obras e o deterioro que a referida reparação poderia ocasionar.

12 – MANTENIMIENTO / MAINTENANCE / MANUTENZIONE / MANUTENÇÃO

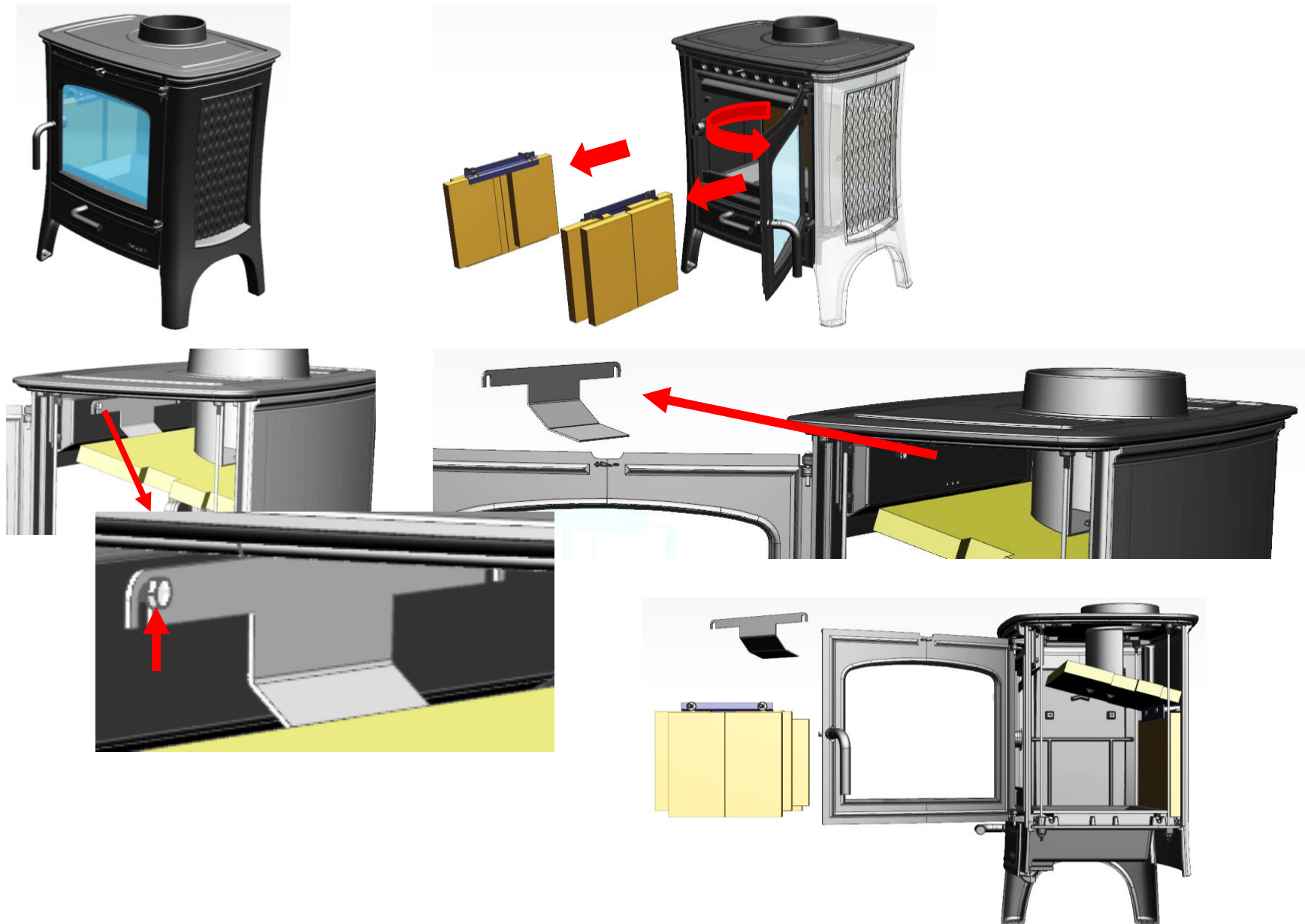

12 – MANTENIMIENTO / MAINTENANCE / MANUTENZIONE / MANUTENÇÃO

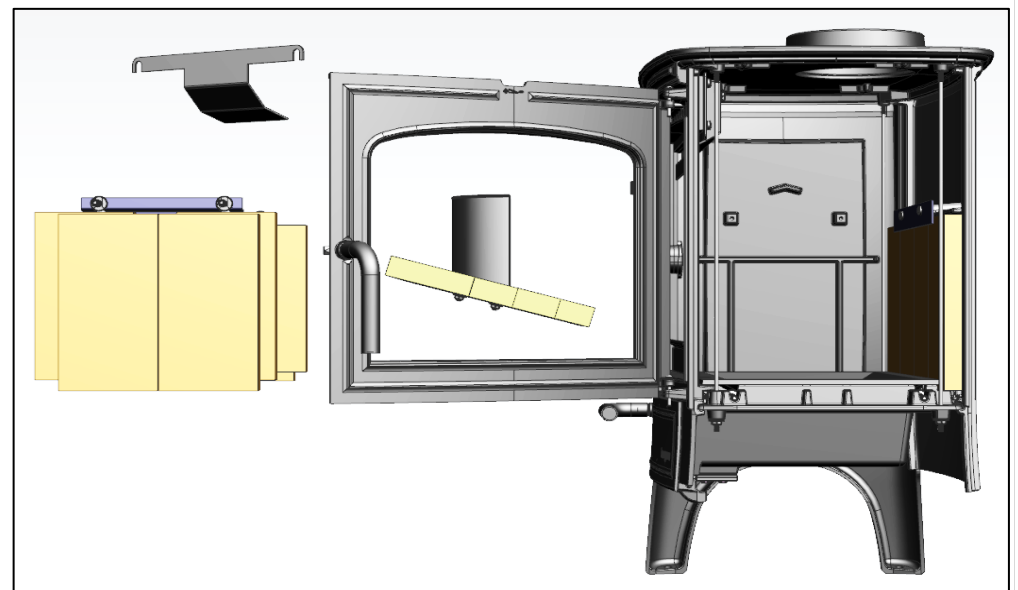
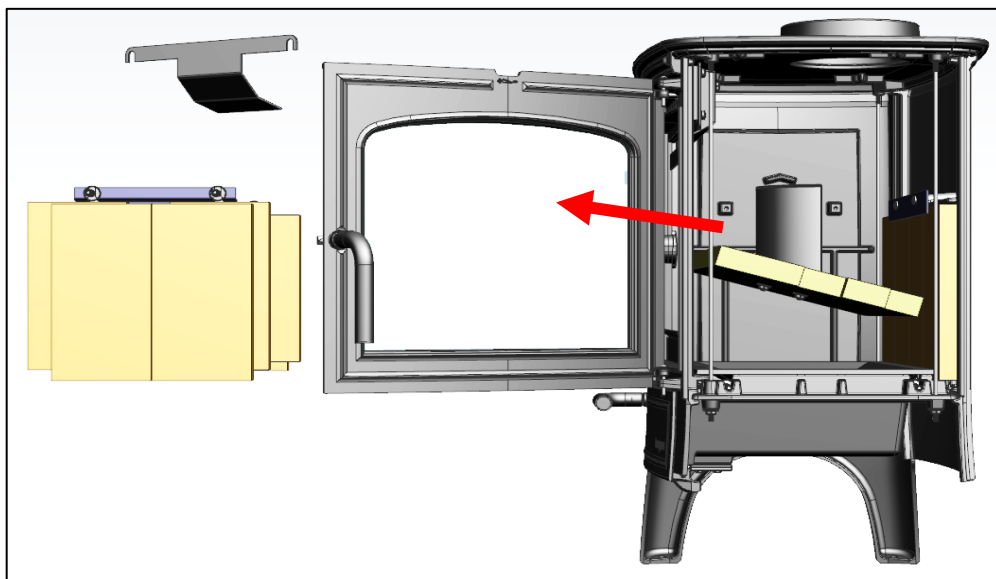
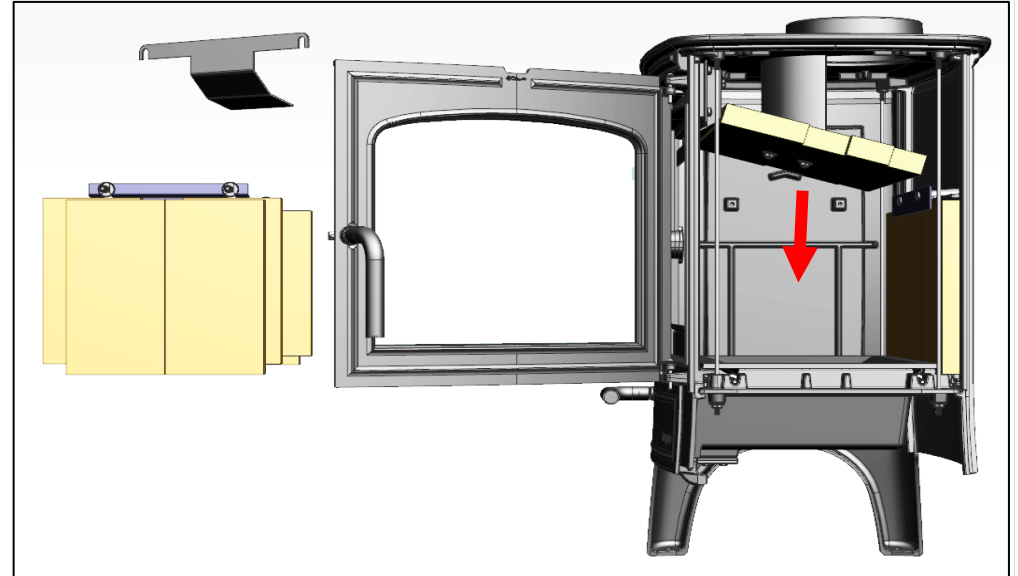
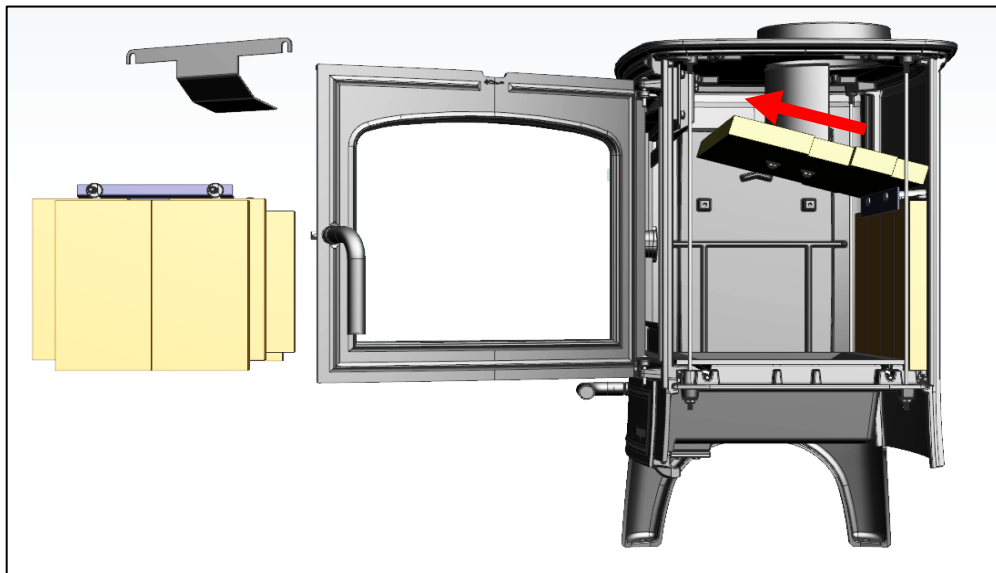

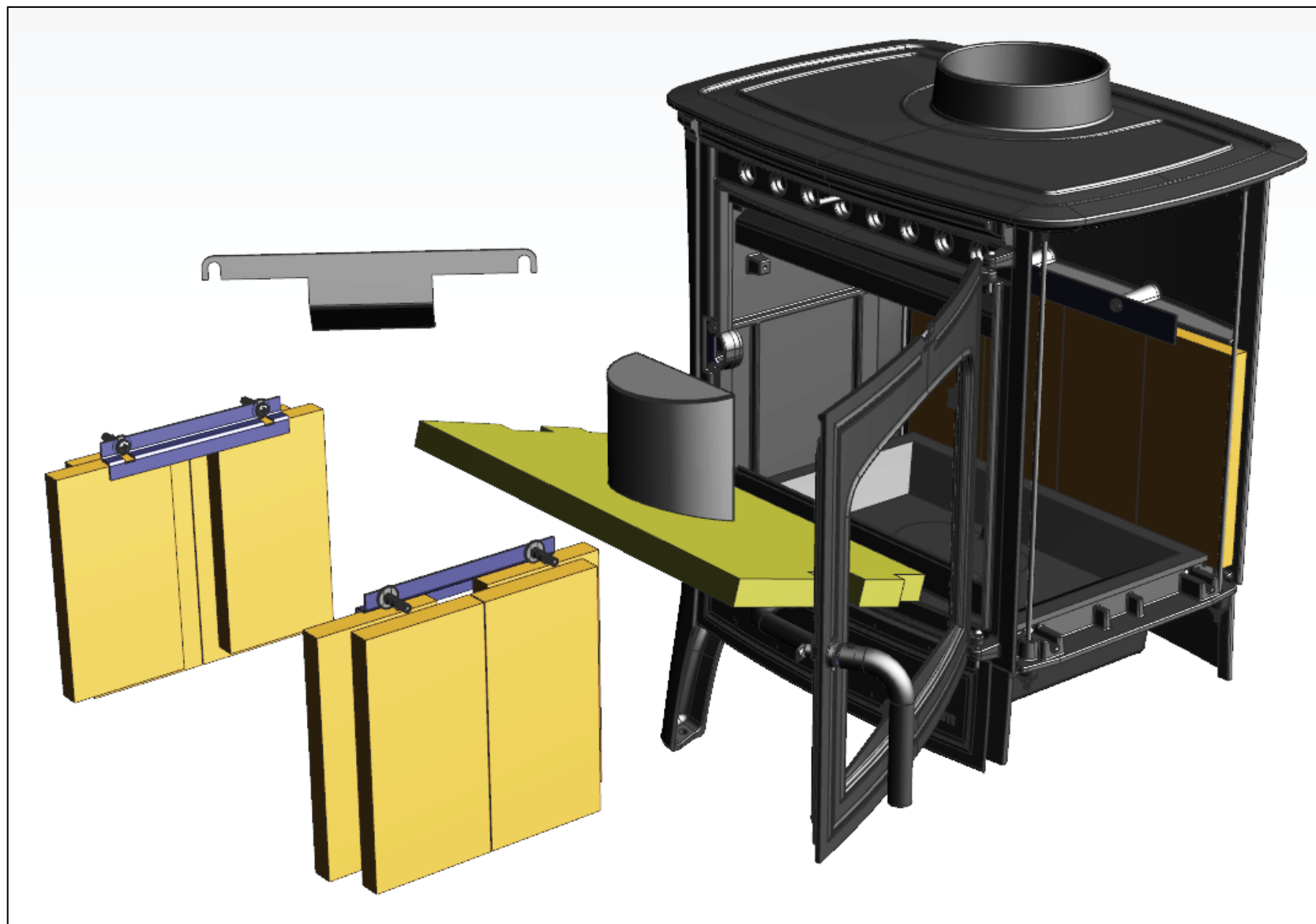

hergom

INDUSTRIAS HERGÓM S.A.

SOTO DE LA MARINA - Cantabria

Apartado de Correos, 208

39080 Santander (ESPAÑA)

Tel.: (942) 587000*

Fax: (942) 587001

Web: <http://www.hergom.com>

E-mail: hergom@hergom.com

C07100AB366

Revisión 6

Fecha de edición: 08/2022